

ELECTRICAL CONNECTIONS

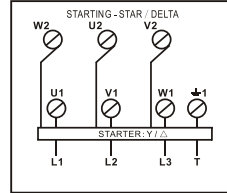

The terminal box of a standard single speed motor contains 6 terminals corresponding to the winding and a ground connector. The admissible fluctuation between rated voltage and mains voltage is $\pm 5\%$; for rated frequency, $\pm 2\%$ is admissible. Observe the connection indications and data on the nameplate. Connection of power supply wiring should be made so as to ensure permanent and reliable contact (with no loose wire ends). Use the appropriate terminal for connection wires and avoid tensile stress in the terminals. Select connection wiring with suitable cross sections for rated frequency and length.

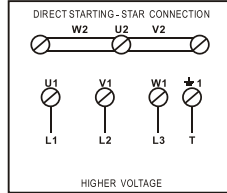
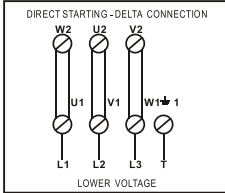

Electrical connections should be made only by qualified personnel. Before proceeding to handle or connect the wires, it is important to make sure there is no risk of electric current running through the wires.

| Key No. | Part Number | Product Description | QTY |
|---------|-------------|--|-----|
| 1 | 89029601 | Lid Fastener with bolt | 2 |
| 2 | 03042010 | Lid | 1 |
| 3 | 02011148 | Lid O-ring | 1 |
| 4 | 03018039 | Basket | 1 |
| 5 | 03042011 | Pre-filter | 1 |
| 6 | 89029602 | M12x30 Bolt & M12 Washer | 4 |
| 7 | 89029603 | M8x25 Bolt & M8 Washer | 8 |
| 8 | 03040202 | 3.0" Inlet Flange (SH55, SH75) | 1 |
| 8 | 03040203 | 3.0" Outlet Flange (SH75, SH100) | 1 |
| 8 | 03040201 | 4.0" Inlet & Outlet Flange | 2 |
| 8 | 03042006 | 3.0" Inlet Flange Adaptor (SH55, SH75) | 1 |
| 8 | 03042012 | 3.0" Outlet Flange (SH75, SH100) | 1 |
| 8 | 03042013 | 4.0" Inlet & Outlet Flange | 1 |
| 9 | 02011179 | 3.0" Flange Washer (SH55, SH75) | 1 |
| 9 | 02011182 | 4.0" Flange Washer (SH75, SH100) | 1 |
| 10 | 03011136 | M10x16 Drain Plug | 2 |
| 11 | 02011168 | Pump Body Seal | 1 |
| 12 | 03042014 | Pump Body (SH55, SH75) | 1 |
| 12 | 03042008 | Pump Body (SH100, SH150) | 1 |
| 13 | 03011138 | M8x30 Bolt | 1 |
| 14 | 03042046 | Cone-shape Washer for SH55, SH75 Impeller | 1 |
| 14 | 03042047 | Cone-shape Washer for SH100, SH150 Impeller | 1 |
| 15 | 02011180 | O-ring for SH55, SH75 Impeller | 1 |
| 15 | 02011181 | O-ring for SH100, SH150 Impeller | 1 |
| 16 | 03042015 | Iron Impeller SH55 HP | 1 |
| 16 | 03042016 | Iron Impeller SH75 HP | 1 |
| 16 | 03042017 | Iron Impeller SH100 HP | 1 |
| 16 | 03042045 | Iron Impeller SH150 HP | 1 |
| 16 | 03018096 | Stainless Steel Impeller SH55 HP | 1 |
| 16 | 03018097 | Stainless Steel Impeller SH75 HP | 1 |
| 16 | 03018098 | Stainless Steel Impeller SH100 HP | 1 |
| 16 | 03018099 | Stainless Steel Impeller SH150 HP | 1 |
| 17 | 04015020 | Mechanical Seal (SH55, SH75) | 1 |
| 17 | 04015021 | Mechanical Seal (SH100, SH150) | 1 |
| 18 | 02011164 | O-ring for SH55, SH75 Flange | 1 |
| 18 | 02011165 | O-ring for SH100, SH150 Flange | 1 |
| 19 | 89029604 | Flange (SH55, SH75) | 1 |
| 19 | 89029605 | Flange (SH100, SH150) | 1 |
| 20 | 02011166 | Motor Slinger (SH55, SH75) | 1 |
| 20 | 02011167 | Motor Slinger (SH100, SH150) | 1 |
| 21 | 04021100 | Motor SH55 HP | 1 |
| 21 | 04021101 | Motor SH75 HP | 1 |
| 21 | 04021102 | Motor SH100 HP | 1 |
| 21 | 04021103 | Motor SH150 HP | 1 |
| 21 | 04021104 | Motor SH55 HP | 1 |
| 21 | 04021105 | Motor SH75 HP | 1 |
| 21 | 04021106 | Motor SH100 HP | 1 |
| 21 | 04021107 | Motor SH150 HP | 1 |
| 22 | 89029606 | M12x30 Motor & Pump Body Assembly Bdt. With Washer | 4 |
| 23 | 89029607 | M10x35 Motor & base Assembly Bolt with Washer | 6 |
| 24 | 03042043 | Base (SH55, SH75) | 1 |
| 24 | 03042044 | Base (SH100, SH150) | 1 |

Pump parts for SH

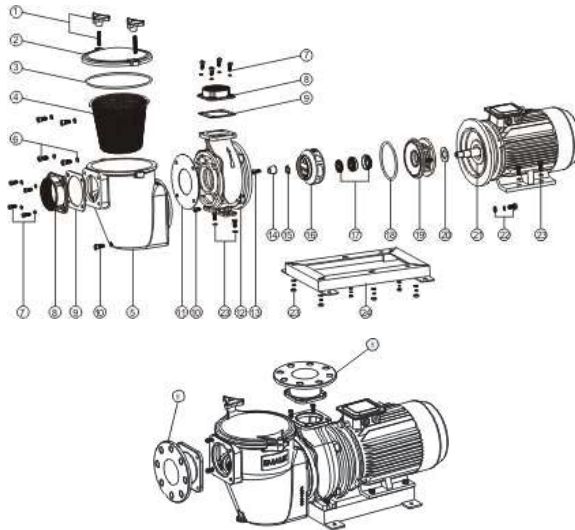

SH Series Centrifugal Pump Installation & Operating Instructions

Model: SH55, SH75, SH100, SH150

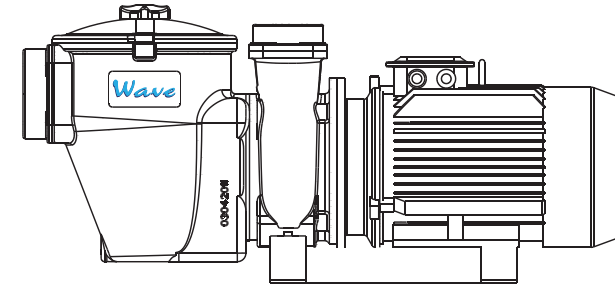

GENERAL INFORMATION

The purpose of the manual is to provide the user with basic information for the installation, start-up and maintenance of the pump.

IMPORTANT

- * This manual is to be read by the person in charge of the assembly, installation and start-up of the pump.
- * This manual is to be kept for future reference.
- * This manual is to be available to all persons in charge of the assembly, installation, operation and maintenance of the pump.
- * It is recommended that this manual is to be kept near the site where the equipment has been installed.

SAFETY WARNING

The following symbols, together with the words "danger" and "warning" indicate the possibility of a hazard resulting from failure to comply with the corresponding instructions.

| | | |
|--|--|--|
| | DANGER Risk of electrification | Failure to observe this indication entails a risk of electrification. |
| | DANGER | Failure to observe this indication entails a risk of harm to persons or facilities. |
| | WARNING | Failure to observe this indication entails a risk of damaging the pump and affecting its function. |

To prevent any types of accident or problem, the safety instructions indicated in this manual should be followed as well as the national safety rules and regulations.

- * Accidental contact should be avoided if cold or hot components can pose a risk.
- * Assembly, Installation, Maintenance and Inspection work should only be carried out by qualified personnel.
- * All maintenance, inspection work and or disassemblment of the pump must be avoided while it is in operation. Moving parts can cause serious damage to property or personal injuries.
- * If the pump is operated with hazardous fluid, the pump should be decontaminised prior to performing any work.
- * Any leak of hazardous fluids should be drained and must comply to the local rules and regulations.
- * Avoid hazards related to electric energy.
- * If the pump will not be installed immediately, it should be stored in a clean, dry place and duly protected.
- * Keep children away from the pump.

⚠ INSTALLATION ⚠

The pump should be installed at a site that is well ventilated and on level ground. The site should be large enough to be able to comfortably assemble or disassemble the pump when required. The pump should in general be located as close to the water source as possible making the suction piping to be short, straight and direct.

When large-size pumps are being installed, they should be fitted with a hoisting block or other similar device enabling them to be moved with ease.

The foundations should be sufficiently solid and firm to rigidly support all foundation anchoring points and absorb all vibrations that may arise without transferring them to the rest of the facility.

Ensure that the electrical supply available agrees with the motor's voltage, phase and cycle, and that wire size is adequate for the HP rating and distance from the power source.

Incorrect suction design is one of the main causes for problems appearing during the pump installations. The suction tube is one of the installation's main components, and it should meet the following conditions in order to avoid future problems.

- 1/ It should be as short and straight as possible.
- 2/ The diameter of the tube should not be smaller than the diameter of the pump's inlet.
- 3/ The suction tube should be fully airtight, if not the entry of air can cause de-priming of the pump.
- 4/ The suction tube should have its own means of support and should not cause tensions or strains to the pump's flange.
- 5/ Minimise the use of elbows, valves, narrowings or choking sections etc which dangerously increase head losses and can cause air pockets as well as entry of air into the piping.
- 6/ Each pump should have its own dedicated suction tube. If for unavoidable reasons it is necessary to connect two or more pumps to a single collector, the collector should have the same diameter from the first to the last outlet and should be sufficiently sized to supply the same flow rate to all pumps.

START-UP

Before start-up, the alignment of the pump should be checked. The tubing should be inspected to ensure that they are properly fitted and tightened and that they do not exert pressure or tension on the pump's suction or discharge flange. The pump should never be operated until the suction tubing and impeller are completely filled with water. The Pump must be primed before start-up. Priming the pump means letting all the air or gas from the suction tubing and pump body.



OPERATION



- * Never run pump dry! Running pump dry may cause damage to the mechanical seal causing leakage and flooding. Fill the pre-filter with water before starting motor.
- * Before removing the pre-filter lid, STOP PUMP, CLOSE GATE VALVES in suction and discharge pipes.
- * Never tighten or loosen screw while the pump is in operation.
- * The suction pipe and the suction inlet in the pool must be free from obstruction.

MAINTENANCE

- * Clean pre-filter (strainer) regularly. Remove all debris and trash that collects in basket. Inspect Pre-filter Lid O'ring regularly and replace as necessary.
- * Keep motor clean, insure air vent (fan cover) are free from obstruction.
- * Pumps have self-lubricating motor bearings. No lubrication is necessary.
- * To optimise the mechanical seal's duration and service, the water used to lubricate it should be fresh and clean. The mechanical seal is usually lubricated by the fluid being pumped.

TROUBLE SHOOTING

Motor Won't Start

- 1/ Check for improper or loose connections, open switches or relays, blown circuit breakers or fuses.
- 2/ Manually check rotation of motor shaft for free movement and lack of obstruction.

Motor Cuts out

- 1/ Wiring, loose connections, etc.
- 2/ Low voltage at motor caused by undersized wiring.
- 3/ Binding or overload. (Amperage reading).

Pump does not reach full speed

- 1/ Low voltage.
- 2/ Wrong voltage connection.

Pump delivers low flow or no water

- 1/ Pump is not primed.
- 2/ Closed valve in suction or discharge line.
- 3/ Undersized pool piping.
- 3/ Clogged, restricted or plugged skimmer basket or pre-filter basket.
- 4/ Air leak in suction (bubbles issuing from

return fittings).

- 5/ Dirty Filter.
- 6/ Low voltage.
- 7/ Clogged or restricted impeller.

High Pump Pressure

- 1/ Discharge valve or inlet fitting closed too much.
- 2/ Return valve too small.
- 3/ Dirty Filter.

Noisy Pump and Motor

- 1/ Air leak in suction causing rumbling in pump.
- 2/ Vibration due to improper mounting, etc.
- 3/ Foreign matter in pump housing.
- 5/ Worn motor bearing(s).
- 6/ Suction line partly plugged.

Air Bubbles at inlet Fittings

- 1/ Leakage of air into suction line at connections or valve stem.
- 2/ Low water level in pool.

Note: If the recommendations in the trouble shooting portion of this manual do not solve your particular problem(s), please contact your local agent or dealer for service.